

### L51K13SOM102

Product	Limit Switch	
Contact	1NO+1NC	
Actuator	Spring Lever	
Actuator Dia	7 mm	
Current	<b>I<sub>e</sub></b>	3 A (240V AC)
Usage Category	AC15	
Mechanical Life	<b>Min Qty</b>	10000000
Electrical Life	<b>Min Qty</b>	1000000
Operating Frequency	<b>On-Off/Hour</b>	Mech. 3000 Elec. 1800
Insulation Voltage	<b>U<sub>i</sub></b>	300 V
Impulse Withstand Voltage	<b>U<sub>imp</sub></b>	2.5 kV
Dielectric Strength (Body-Contact)	1.890V AC	
Dielectric Strength (Contact-Contact)	1.890V AC	
Isolation Resistance	10 MΩ (500 V DC)	
Operating Temperature	-25 / + 80 °C	
Pollution Degree	3	
Protection Degree	IP65	
Contact Material	AgNi	
Cable Section	1-2.5 mm <sup>2</sup>	
Screw Torque	1.5Nm	
Short Circuit Breaking Capacity	<b>I<sub>cs</sub></b>	1 kA
Production Time	31.12.1899 00:00:00	
Serial	L51 Metal Body	
Contact Action	Snap Action	
Actuator Material	Metal Blunt	
Specifications	Metal Body and Cover	
	1 side PG13,5 or M20x1,5 hole	

Various actuator options with wide sensitive contact block alternatives for all kind of applications

**Standards / Certificates** TS EN 60947-5-1 UL 508 VDE 0660



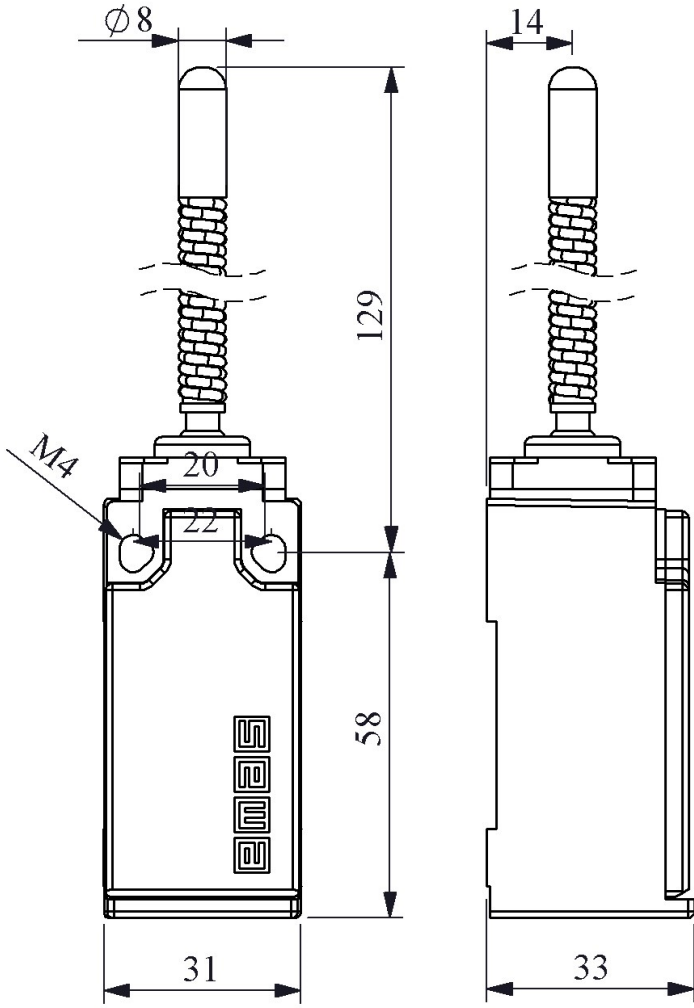

Devre Şeması

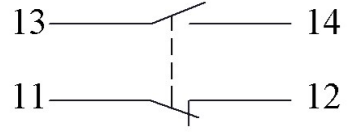

Ani Hareketli



Akış Diyagramı